

WD1/WD2/WD3 HYDRA-D Desiccant Dryers G1 or 8, 12 mm PIF connections

- High efficiency moisture removal**
- Integral inlet and outlet filtration**
- Reliable PLC control**
- Energy saving option - dew point sensing for lowest possible purge air use**
- Replacement desiccant cartridges for quick and easy servicing**
- Water and dirt contamination in outlet air both within ISO 8573-1 class 2: -40°C PDP for water and 1 micron particulate**
- Alternative dew point settings**



For systems with oil lubricated compressors or oil in inlet air supply coalescing filter assemblies are needed

Technical features

Medium:

Compressed air

Air quality:

Air Quality: Within ISO 8573-1, class 2 water [-40°C pressure dew point] and class 2 particulate [1 micron]

Operating pressure:

4 ... 16 bar

Flow:

see table below

Operation:

Pressure swing adsorption

Purge air:

average 15 %

Power supply:

100 ... 240 V a.c. - 50/60 Hz

Protection class:

IP54

Noise level:

< 60 dB(a) WD1

< 90 dB(a) WD2,WD3

Ambient/Media temperature:

+2 ... +50°C

Servicing:

12.000 hours

Materials

Body: Powder coated high tensile aluminium

End cap: Glass filled nylon

Valves: Brass

Filters: Borosilicate glass microfibres

Bracket: Epoxy coated mild steel

Technical data - standard models

Symbol	Port size	Maximum flow *1)		Outlet l/s	Weight (kg)	Drawing No.	Service kits	Model *2)	
		Inlet l/s	scfm						
	8 mm PIF	1,4	3	1,1	2,4	8,3	1	WD1D-KITA	WD1D-8DA-N1A
	8 mm PIF	2,4	5	1,9	4	8,3	1	WD1D-KITB	WD1D-8DA-N1B
	8 mm PIF	4,7	10	3,8	8	13	1	WD1D-KITC	WD1D-8DA-N1C
	8 mm PIF	7,2	15	5,6	12	16	1	WD1D-KITF	WD1D-8DA-N1F
	12 mm PIF	11,4	24	9,2	19	19	1	WD1D-KITG	WD1D-BDA-N1G
	G1	16,1	34	13,1	28	40	2	WD2D-KITH	WD2D-8GA-N1H
	G1	19,4	41	16,1	34	40	2	WD2D-KITJ	WD2D-8GA-N1J
	G1	25,0	53	20,3	43	54	2	WD2D-KITK	WD2D-8GA-N1K
	G1	31,1	66	25,6	54	54	2	WD2D-KITL	WD2D-8GA-N1L
	G1	41,7	88	33,9	72	64	3	WD3D-KITM	WD3D-8GA-N1M
	G1	50,0	106	40,6	86	78	3	WD3D-KITN	WD3D-8GA-N1N
	G1	62,2	132	50,8	108	95	3	WD3D-KITP	WD3D-8GA-N1P
	G1	83,6	177	68,1	144	119	3	WD3D-KITQ	WD3D-8GA-N1Q

*1) Maximum rated flow to maintain -40°C PDP with inlet pressure of 7 bar and 35°C

*2) Energy saving models: Please change the letter 'A' on the 8th position into 'B' - Example: WD1D-8DB-N1A

Approximate correction factors

Flow rates differ with inlet pressure, inlet pressure and outlet pressure dew point

Inlet pressure correction (K1)	Pressure (bar)	4	5	6	7	8	9	10	11	12	13	14	15	16
Factor		0,63	0,75	0,88	1	1,13	1,25	1,38	1,5	1,63	1,75	1,88	2,0	2,1
Inlet temperature correction (K2)	Temperature °C	25	35	40	45	50								
Factor		1	1	0,97	0,88	0,73								
Outlet DEW point correction (K3)	PDP °C	-20	-40	-70										
Factor		1,1	1	0,7										

Approx max flow = outlet (from table) x K1 x K2 x K3
Contact www.norgren.com/dryers for confirmation

Pre-filters for oil removal in inlet air.

	General purpose filters	Oil removal filters	Flow up to *1) (l/s)
	F07	F39	3
	F72G	F72C	10
	F64G (F74G)	F64C (F74C)	16,5
	F64G (F74G)	F64H (F74H)	25
	F68G (F17)	F68C (F46)	35
	F68G	F68H	63

*1) Max flow to keep remaining oil content below 0,01mg/m³ at 7 bar

Spares kits

Dryer series	Inlet valve kit	Exhaust valve kit	Pilot valve kit	Check valve kit	Dewpoint sensor kit
WD1	—	WD1D-KITGV	—	—	WD3D-KITQS
WD2	WD2D-KITLV	WD3D-KITQW	—	WD3D-KITQY	WD3D-KITQS
WD3	WD3D-KITQV	WD3D-KITQW	WD3D-KITQX	WD3D-KITQY	WD3D-KITQS

Dimensions WD1 series

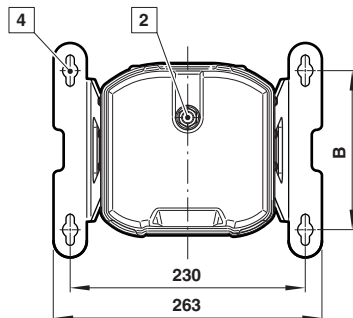
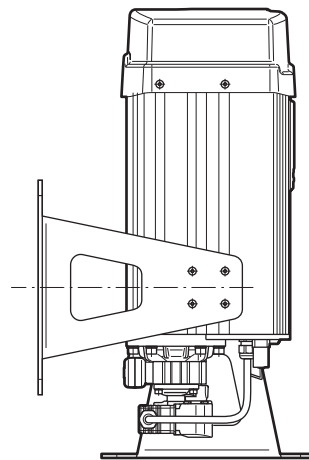
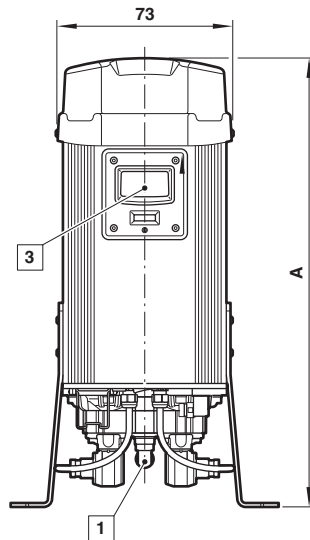
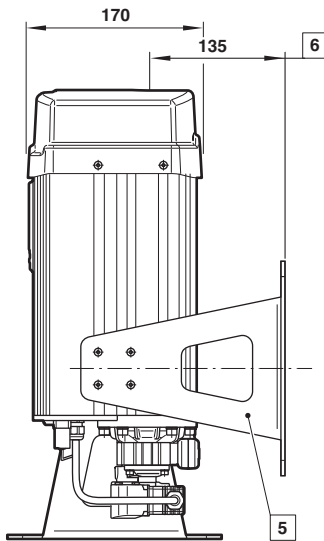
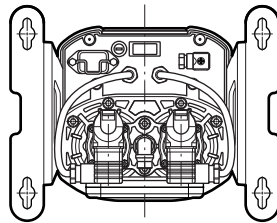

- 1 Inlet port
- 2 Outlet port
- 3 Display
- 4 Mounting holes Ø 15 mm - slot width 8 mm
- 5 Standard brackets allow both floor and wall mounting
- 6 Dimension to centre of inlet & outlet

A	B	Model
447	156	WD1D-8DB-N1A
447	156	WD1D-8DB-N1B
647	156	WD1D-8DB-N1C
897	276	WD1D-8DB-N1F
1097	276	WD1D-8DB-N1G

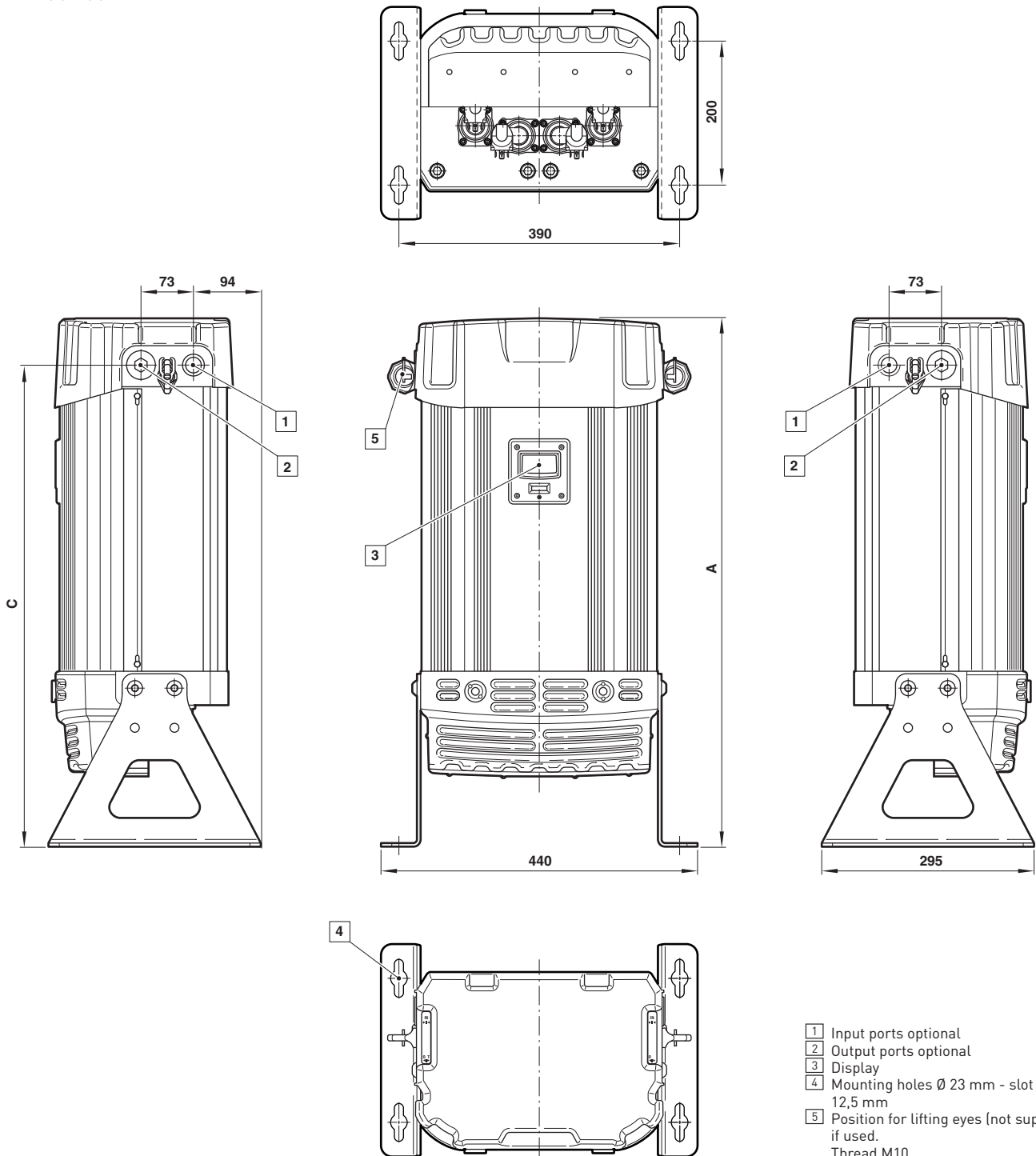
**Dimensions
WD2 series**

- 1 Input ports optional
- 2 Output ports optional
- 3 Display
- 4 Mounting holes \varnothing 23 mm - slot width 12,5 mm
- 5 Position for lifting eyes (not supplied), if used.
Thread M10
Eyes must be removed prior to connecting piping.

A	C	Model
734	670	WD2D-8GA-N1H
734	670	WD2D-8GA-N1J
914	850	WD2D-8GA-N1K
914	850	WD2D-8GA-N1L

Dimensions
WD3 series

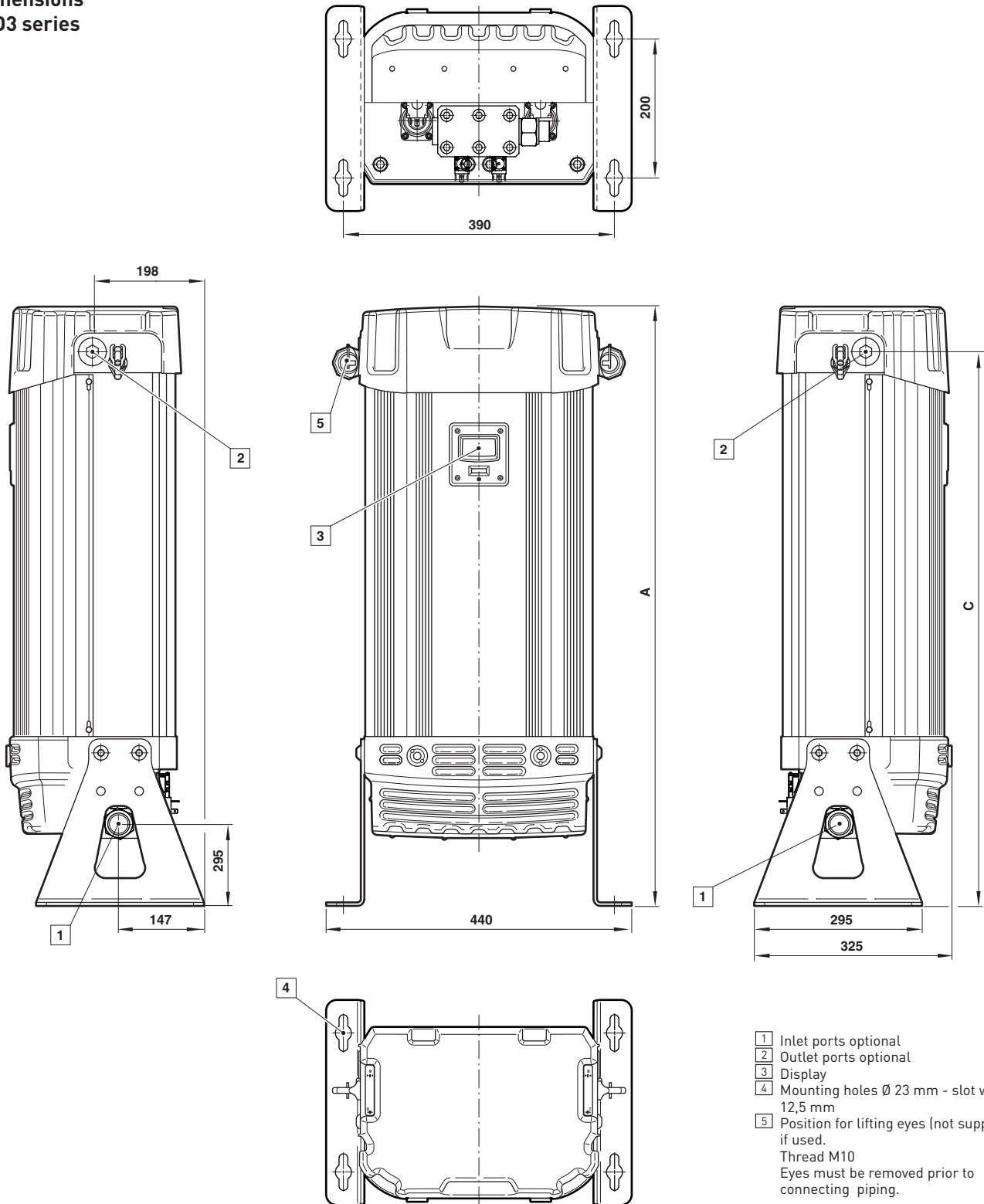

- 1 Inlet ports optional
- 2 Outlet ports optional
- 3 Display
- 4 Mounting holes \varnothing 23 mm - slot width 12,5 mm
- 5 Position for lifting eyes (not supplied), if used.
Thread M10
Eyes must be removed prior to connecting piping.

A	C	Model
1089	1025	WD3D-8GA-N1M
1239	1175	WD3D-8GA-N1N
1489	1425	WD3D-8GA-N1P
1839	1775	WD3D-8GA-N1Q

Warning

These products are intended for use in industrial compressed air systems only. Do not use these products where values can exceed those listed under »**Technical features/data**«.

Before using these products with fluids other than those specified, for non-industrial applications, life-support systems, or other applications not within published specifications, consult NORGREN.

Through misuse, age, or malfunction, components used in fluid power systems can fail in various modes.

The system designer is warned to consider the failure modes of all component parts used in fluid power systems and to provide adequate safeguards to prevent personal injury or damage to equipment in the event of such failure.

System designers must provide a warning to end users in the system instructional manual if protection against a failure mode cannot be adequately provided.

System designers and end users are cautioned to review specific warnings found in instruction sheets packed and shipped with these products.